

ICC-ES Evaluation Report

ESR-2851*

Issued May 1, 2009

This report is subject to re-examination in one year.

www.icc-es.org | (800) 423-6587 | (562) 699-0543

A Subsidiary of the International Code Council®

DIVISION: 09—FINISHES
Section: 09220—Portland Cement Plaster

REPORT HOLDER:

FORMULATED SOLUTIONS, LLC
25-44 BOROUGH PLACE
WOODSIDE, NEW YORK 11377-7889
(718) 267-6380
www.TessFinishes.com

EVALUATION SUBJECT:

**TESS™ THINSET EXTERIOR SURFACING SYSTEM ONE
 COAT STUCCO**

1.0 EVALUATION SCOPE
Compliance with the following codes:

- 2006 *International Building Code*® (IBC)
- 2006 *International Residential Code*® (IRC)

Properties evaluated:

- Structural
- Durability

2.0 USES

TESS™ Thinset Exterior Surfacing System is a cementitious one-coat stucco wall coating system installed on exterior walls of wood or steel studs, concrete or concrete masonry construction. The system is an alternative to exterior wall coverings specified in IBC Chapter 25 and IRC Section R703. The system is recognized for use on wood or steel-stud framed walls of Type V-B construction, under the IBC, and dwellings under the IRC. The system may also be applied over concrete or masonry walls with or without wire fabric or metal lath.

3.0 DESCRIPTION
3.1 General:

TESS™ is an exterior fiber-reinforced nonstructural one-coat system. The system consists of a proprietary mixture of portland cement, sand, fibers and proprietary ingredients reinforced with wire fabric or metal lath and applied to substrates of expanded polystyrene (EPS) insulation board, gypsum sheathing board, or wood structural panel sheathing on exterior walls of wood or steel stud construction, or directly to exterior walls constructed of concrete or concrete masonry.

3.2 Materials:

3.2.1 TESS™ One Coat Stucco Sanded: The stucco is a factory-prepared mixture of Type I portland cement complying with ASTM C 150, sand, chopped polypropylene fibers, and proprietary additives. The mixture is packaged in 80-pound (36.3 kg) bags. One to 1½ gallons (3.8 to 5.7 L) of water must be added for each bag in the field and mixed in accordance with the manufacturer's recommendations.

3.2.2 TESS™ One Coat Stucco Unsanded: The TESS One Coat Stucco Unsanded mixture is identical to the sanded mixture described in Section 3.2.2 with the exception that sand is not included in the packaging. The mixture is packaged in 80-pound (36.3 kg) bags. Three to 3½ gallons (11.4 to 15.1 L) of water and 200 to 220 pounds (90.7 to 100 kg) of plaster sand complying with Section 3.2.5 must be added for each bag in the field and mixed in accordance with the manufacturer's recommendations.

3.2.3 TESS™ Primer: The primer is a proprietary factory-prepared mixture of latex polymer and portland cement, packaged in 20-pound (9.1 kg) bags. One and a half gallons (5.7 L) of water must be added for each bag in the field and mixed in accordance with the manufacturer's recommendations.

3.2.4 TESS™ Finish Coat: The finish is a factory-prepared mixture packaged in 44-pound (20 kg) bags. One to 1¼ gallons (3.8 to 4.7 L) of water must be added for each bag in the field and mixed in accordance with the manufacturer's recommendations.

3.2.5 Sand: Sand must be clean and free from deleterious amounts of loam, clay, silt, soluble salts, and organic matter. Sampling and testing must comply with ASTM C 144 and within the following limits:

RETAINED ON U.S. STANDARD SIEVE	PERCENT RETAINED BY WEIGHT ±2 PERCENT	
	Min.	Max.
No. 4	-	0
No. 8	0	5
No. 16	0	30
No. 30	25	60
No. 50	65	90
No. 100	85	98
No. 200	95	100

*Revised July 2009

3.2.6 Insulation Board: Expanded polystyrene (EPS) insulation board must have a minimum nominal density of 1.5 pounds per cubic foot (24 kg/m³), a flame-spread index of 25 or less and a smoke-developed index of 450 or less when tested in accordance with ASTM E 84 and must comply with ASTM C 578 as Type II Boards. Boards installed without sheathing over open framing must be 1 inch to 1½ inches (25.4 to 38.1 mm) thick and have ¾-inch-high (9.5 mm) tongues with compatible grooves for horizontal joints. See Figure 1 for joint detail. All boards must be recognized in a current ICC-ES evaluation report. See Section 7.2 for board identification. Over solid substrates, a square-edge foam plastic board with a minimum ½-inch (12.7 mm) thickness and a minimum nominal density of 1 pcf (16 kg/m³) is permitted.

3.2.7 Lath:

3.2.7.1 Wire Fabric Lath: Wire fabric lath must comply with the ICC-ES Acceptance Criteria for Metal Plaster Bases (Lath) (AC191) and must be recognized in a current ICC-ES evaluation report. Minimum No. 20 gage [0.035 inch (0.89 mm)], 1-inch (25.4 mm), galvanized steel, woven-wire fabric must be used. Lath must be furred when applied over all substrates except unbacked polystyrene board. Furring must comply with the following requirements:

- a. When maximum total coating thickness is ½ inch (12.7 mm) or less, the body of the lath must be furred a minimum of ⅛ inch (3.2 mm) from the substrate after installation.
- b. When the total coating thickness is greater than ½ inch (12.7 mm), No. 17 gage [0.058 inch (1.47mm)] by 1½-inch (38 mm), woven-wire fabric lath must be used. The body of the lath must be furred a minimum of ¼ inch (6.4 mm) from the substrate after installation.

3.2.7.2 Metal Lath: Metal lath must comply with AC191 and IBC Table 2507.2 or IRC Section R703.6. Furring requirements must be as set forth in Section 3.2.6.1 for wire fabric lath.

3.2.8 Gypsum Sheathing Board: The gypsum sheathing board must be water-resistant core gypsum sheathing complying with ASTM C 79 or C 1396, or glass mat gypsum substrate complying with ASTM C 1177, and must be recognized in a current ICC-ES evaluation report.

3.2.9 Wood-based Structural Panels: The plywood or oriented strand board (OSB) panels must be a minimum of ⅝ inch thick (7.9 mm) and must be exterior grade or Exposure 1, complying with U.S. Department of Commerce Product Standard PS-1 or PS-2, as applicable.

3.2.10 Caulking: The caulking must be polyurethane, polyurethane modified, polysulfide, or silyl-terminated polyether elastomeric sealants complying with ASTM C 920.

3.2.11 Weather Protection:

3.2.11.1 Water-resistive Barrier: A water-resistive barrier consisting of DuPont™ Tyvek® StuccoWrap® - Style 1062X, as recognized in ICC-ES [ESR-2375](#), is required. Application of the barrier must be in accordance with the manufacturer's published installation instructions and [ESR-2375](#). When use is over wood-based sheathing, two layers of the water-resistive barrier must be applied over the sheathing in accordance with IBC Section 2510.6 or IRC Section R703.6.3, or one layer of EPS insulation board having horizontal tongue-and-groove edges as described in Section 3.2.6 of this report is applied over one layer of the water-resistive barrier.

3.2.11.2 Vapor Retarder: Under the IBC, protection against condensation must be provided in accordance with IBC Section 1403.2. Under the IRC, a vapor retarder complying with IRC Section R318.1 must be provided, unless its omission is permitted under the exceptions in IRC Section R318.1.

3.2.11.3 Flashing: Flashing complying with IBC Section 1405.3 or IRC Section R703.8, as applicable, must be provided. Where membrane flashing is used, it must be a self-adhering, flexible rubberized asphalt and polyethylene material, 0.030 inch (0.76 mm) thick and shingle-lapped with the water-resistive barrier. Rigid flashing must be sloped toward the exterior, with an upturned leg on the interior side and at the ends. Flashing must extend beyond the surface of the exterior wall.

3.2.11.4 Trim and Accessories: All trim, screeds and corner reinforcement must be of corrosion-resistant material.

4.0 DESIGN AND INSTALLATION

4.1 General:

The exterior cementitious coating is applied by hand-troweling in one coat to a minimum ¾-inch (9.5 mm) thickness, unless noted otherwise. The lath must be embedded in the minimum coating thickness and therefore cannot be exposed. Flashing, corner reinforcement, metal trim and weep screeds must be installed as shown in Figure 2. The water-resistive barrier must be applied as set forth in Section 3.2.11.1. The coating is applied at ambient air temperatures ranging from 40°F to 100°F (4°C to 38°C) by applicators approved by Formulated Solutions, LLC. An installation card, as illustrated in Figure 3, must be on the jobsite with the name of the applicator and the product to be used before any water-resistive barrier or exterior sheathing is installed. Also, see Section 5.5 of this report.

4.2 Application over Open Framing:

4.2.1 Foam Plastic Insulation Board: The water-resistive barrier is placed over open studs spaced a maximum of 16 inches (406 mm) on center. The EPS board, as described in Section 3.2.6, is attached using galvanized staples, roofing nails or screws. Vertical butt joints must be staggered at least one stud space from adjacent courses, and must occur directly over studs.

The lath must then be applied tightly over the foam plastic insulation board and fastened through the board and water-resistive barrier to wood studs, using No. 11 gage galvanized roofing nails or No. 16 gage corrosion-resistant staples spaced a maximum of 6 inches (152 mm) on center with a minimum 1-inch (25 mm) penetration into the studs. Staples must have a minimum crown width of ⅞ inch (11 mm). The wood species must have a minimum specific gravity of 0.42. Care must be taken to avoid overdriving fasteners.

The TESS one coat stucco system may also be applied to minimum No. 20 gage [0.0396 inch base-metal thickness (1.01 mm)] steel studs spaced a maximum of 16 inches (406 mm) on center. Lath must be applied tightly over the foam plastic board and must be fastened through the board and water-resistive barrier to the metal studs, using minimum No. 8, corrosion-resistant, self-drilling, tapping screws having 0.40 inch-diameter (10.2 mm) wafer-heads, at 7 inches (178 mm) on center to all studs and track. Screws must penetrate the studs a minimum of ½ inch (12.7 mm).

The lath must be applied with 1½-inch (38 mm) end and side laps. Wall bracing in accordance with Section 2308.9.3 or 2308.12 of the IBC, or Section R602.10 or R602.11 of the IRC, or an acceptable alternate is required.

Square wall corners must be covered with metal corner reinforcement. Interior wall corners may have a double layer of metal lath. Weep screeds must comply with, and be installed at the bottom of the wall in accordance with, Section 2512.1.2 of the IBC or Section R703.6.2 of the IRC. At windows and doors, flashing as described in Section 3.2.11.3 of this report is required. Holes for hose bibs, electrical panels and other penetrations of substrate surfaces, except those caused by fasteners, must be flashed in accordance with the code. The coating must then be applied as described in Section 4.1.

4.3 Application over Solid Backing

4.3.1 Gypsum Sheathing: Minimum $\frac{1}{2}$ -inch-thick (12.7 mm), water-resistant treated core gypsum sheathing, described in Section 3.2.5 of this report, must be installed directly over wood studs spaced a maximum of 24 inches (610 mm) on center. Gypsum sheathing must be fastened in accordance with ASTM C 1280 (IBC) or Table R702.3.5 of the IRC. A water-resistive barrier must be applied over the gypsum sheathing in accordance with Section 3.2.11.1 of this report before application of lath or optional insulation board. The lath must be then attached to studs through the sheathing, with fasteners and spacings as described for insulation board in Section 4.2.1. All walls must be braced in accordance with the applicable code. Exposed sheathing edges must be protected. Holes in the substrate surface must be flashed in accordance with the code, and the coating must be applied as described in Sections 4.1 and 4.2.

The gypsum sheathing, optional foam plastic insulation board, lath and coating may be applied to minimum No. 20 gage [0.0396 inch base-metal thickness (1.01 mm)] steel studs spaced a maximum of 16 inches (406 mm) on center, provided the fasteners and their placement are as set forth in Section 4.2.1 for steel studs.

4.3.2 Wood-based Sheathing: Wood-based sheathing must be applied directly to studs under the conditions set forth in Section 3.2.9 of this report and either Table 2308.9.3(3) of the IBC or Table 602.3(3) of the IRC, as applicable. The water-resistive barrier must be applied over the sheathing under the conditions set forth in Section 3.2.11.1 prior to installation of the lath or optional foam board. The lath must then be attached to the studs through the sheathing with fasteners and spacing as described in Section 4.2.1.

4.3.3 Concrete and Masonry: Surface preparation must be in accordance with IBC Section 2510.7. The surface must be clean, free of dust and other particles, and sufficiently damp to ensure proper bonding. The TESS coating is applied directly to the prepared surface at a minimum thickness of $\frac{3}{8}$ inch (9.5 mm), in accordance with applicable provisions of Section 4.1.

4.4 Miscellaneous:

4.4.1 Inspection Requirements: Building department inspection is required on lath installation prior to application of the coatings, in accordance with the applicable code.

4.4.2 Control Joints: Control joints must be installed as specified by the architect, designer, builder or exterior coating manufacturer, in that order. In the absence of other details, conventional three-coat plastering details must be used.

4.4.3 Curing: Moist curing must be provided for 48 to 72 hours, depending on temperature, after coating application.

4.4.4 Soffits: The system is not recognized for application to soffits.

4.4.5 Sills: The system is not recognized for application to sills.

5.0 CONDITIONS OF USE

The TESS™ system described in this report complies with, or is a suitable alternative to what is specified in, those codes listed in Section 1.0 of this report, subject to the following conditions:

- 5.1 Materials and methods of installation must comply with this report and the manufacturer's published installation instructions. A copy of these instructions must be available at all times on the jobsite during installation. In the event of a conflict between the installation instructions and this report, this report governs.
- 5.2 Installation is by contractors approved by Formulated Solutions, LLC.
- 5.3 The system is limited to Type V-B construction (IBC) and construction permitted by the IRC.
- 5.4 The interior of the building must be separated from the foam plastic boards by a thermal barrier complying with IBC Section 2603.4 or IRC Section R314.4 and IRC Table R702.3.5.
- 5.5 An installation card, such as that shown in Figure 3 of this report, must be completed and left at the jobsite for the owner, and a copy filed with the building department.
- 5.6 Inspections must be performed in accordance with Section 4.4.1 of this report.
- 5.7 In areas where the probability of termite infestation is very heavy in accordance with IBC Section 2603.8 or IRC Section R320.5, foam plastic insulation boards must not be placed on exterior walls located within 6 inches (152 mm) of the ground.
- 5.8 The allowable wind load on the system with studs at a maximum of 16 inches (406 mm) on center is 25 psf (1.2 kPa), positive or negative. Supporting framing must be adequate to resist the required wind load and must be designed based on fastener capacity when installed over concrete masonry.

6.0 EVIDENCE SUBMITTED

Data in accordance with the ICC-ES Acceptance Criteria for Cementitious Exterior Wall Coatings (AC11), dated June 2007 (editorially revised April 2008).

7.0 IDENTIFICATION

- 7.1 The factory-prepared mix is delivered to the jobsite in water-resistant bags with labels bearing the following information:
 - a. Name and address of the manufacturer (Formulated Solutions, LLC) and the evaluation report number (ESR-2851)
 - b. Identification of components
 - c. Weight of packaged mix
 - d. Storage instructions
 - e. Maximum amount of water and other components that may be added, and conditions that must be considered in determining actual amount
 - f. Curing instructions
- 7.2 Polystyrene foam plastic insulation boards must be identified in accordance with their respective ICC-ES evaluation reports. Additionally, the board density must be noted.

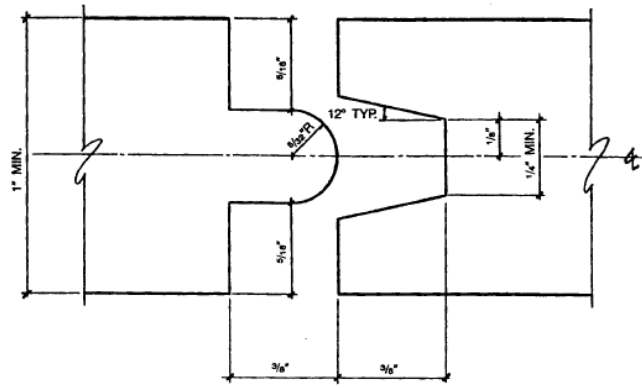

FIGURE 1—BOARD TONGUE-AND-GROOVE JOINT

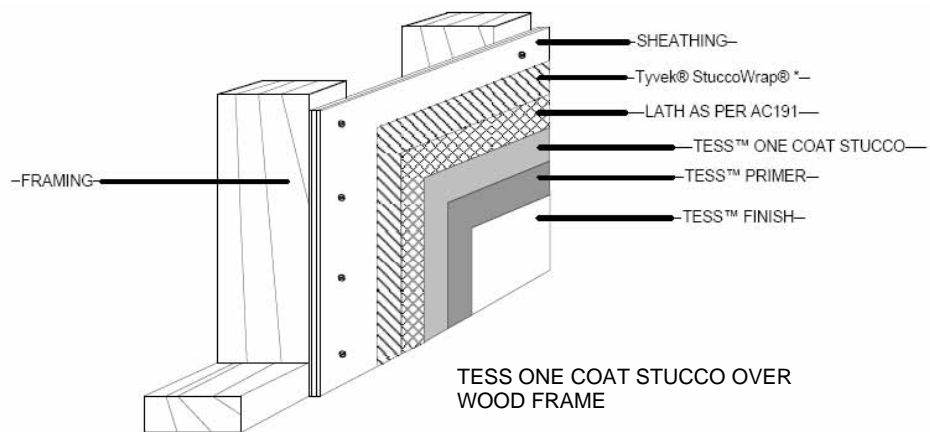
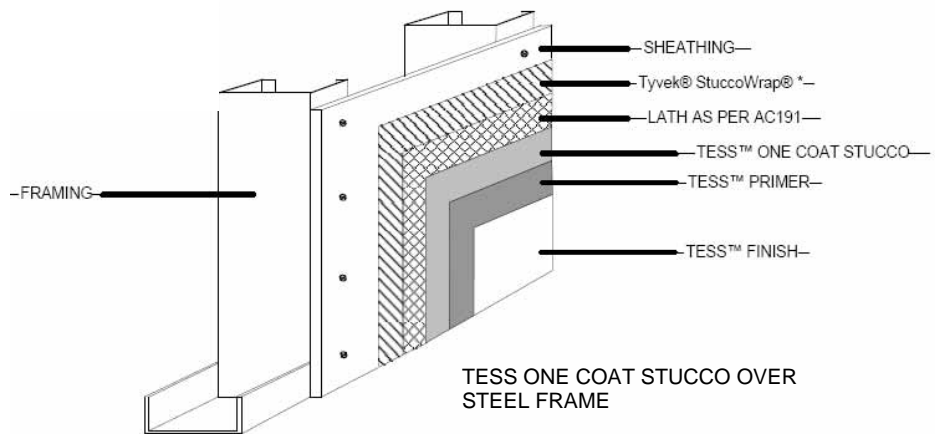
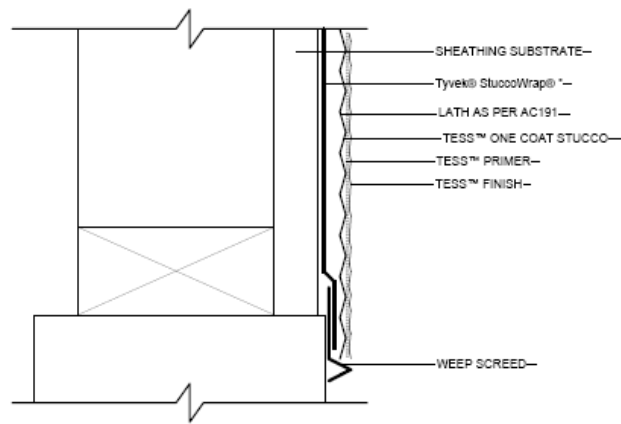
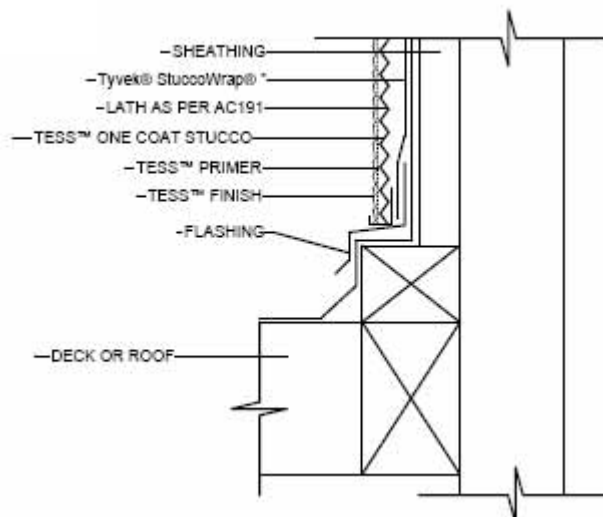

FIGURE 2—TYPICAL DETAILS FOR TESS™ THINSET EXTERIOR SURFACING SYSTEM ONE COAT STUCCO



TERMINATION AT SHEATHED FRAME BASE



TERMINATION AT GABLE OR DECK FLASHING

FIGURE 2—TYPICAL DETAILS FOR TESS™ THINSET EXTERIOR SURFACING SYSTEM ONE COAT STUCCO (Continued)

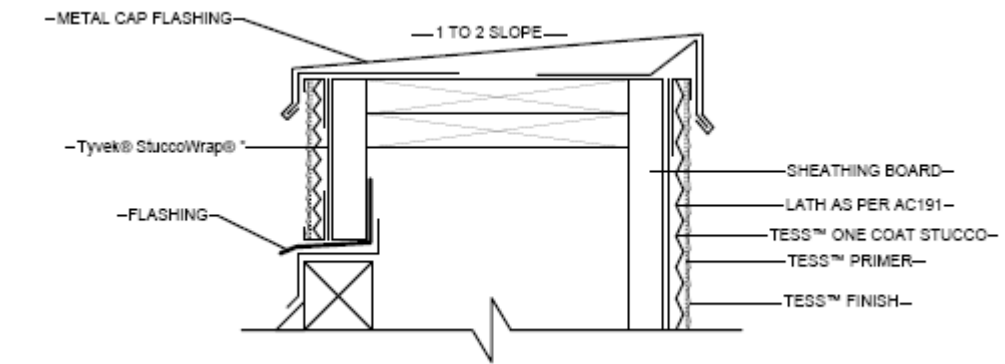

WOOD FRAME – DOUBLE FACED PARAPET

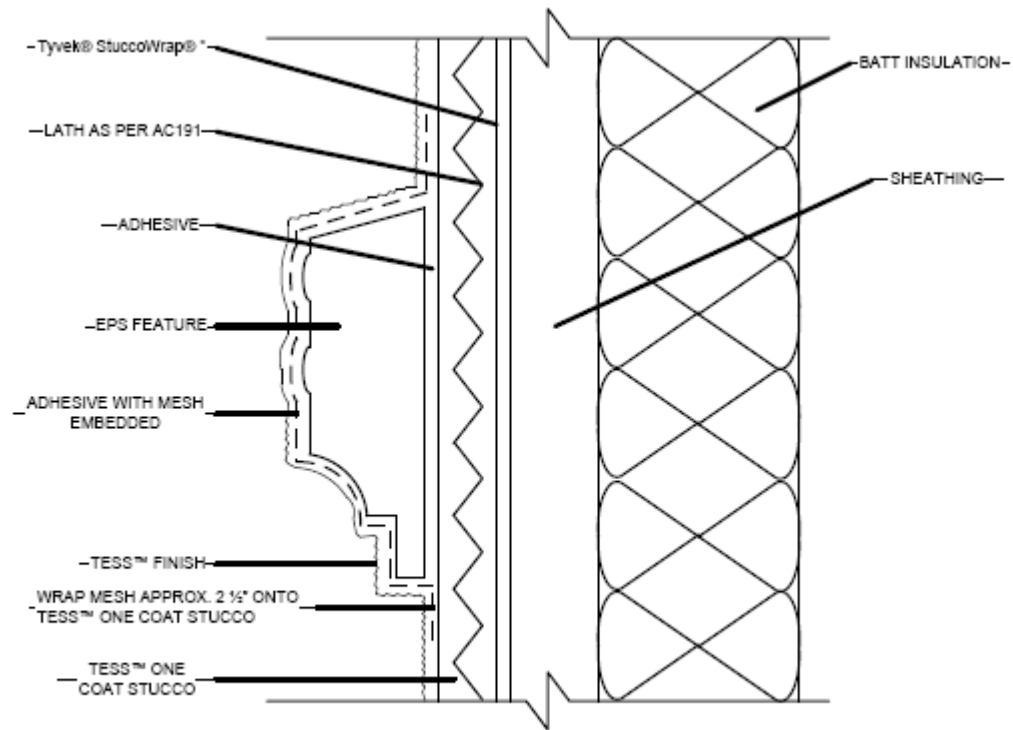

NOTE: WALL CONSTRUCTION SHALL MEET REQUIREMENTS OF LOCAL BUILDING CODE.

FEATHER BASE COAT ONTO TESS ONE COAT

FIGURE 2—TYPICAL DETAILS FOR TESS™ THINSET EXTERIOR SURFACING SYSTEM ONE COAT STUCCO (Continued)

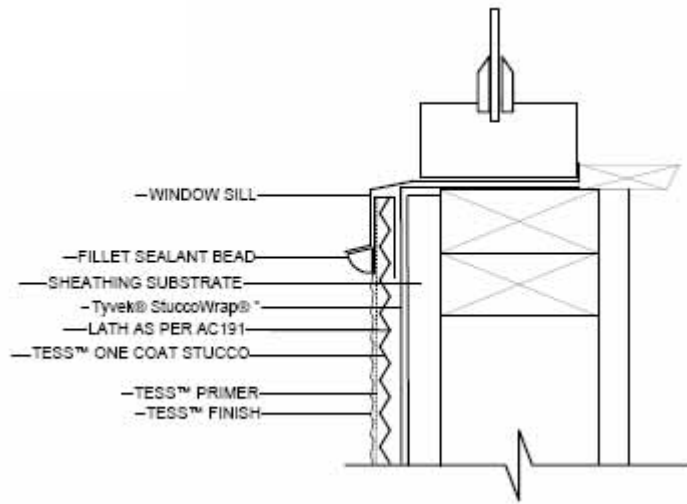

WINDOW SILL WITH NO INSULATION BOARD

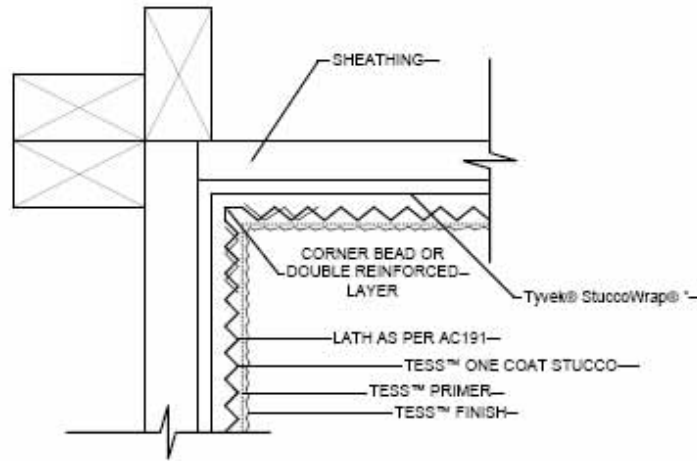

INSIDE CORNER

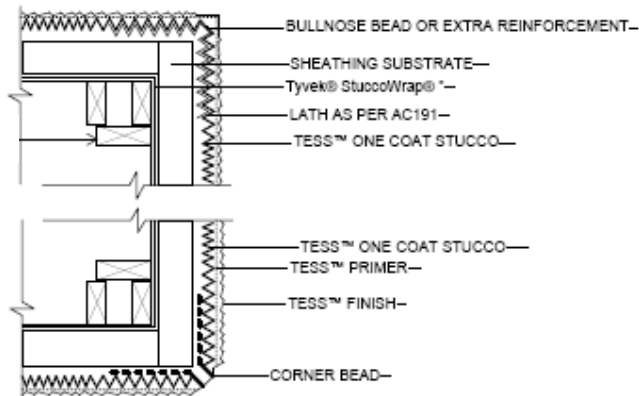

BULLNOSE CORNER – SQUARE CORNER ON INSULATION BOARD

FIGURE 2—TYPICAL DETAILS FOR TESS™ THINSET EXTERIOR SURFACING SYSTEM ONE COAT STUCCO (Continued)

**INSTALLATION CARD
TESS™ ONE COAT SYSTEM
FORMULATED SYSTEMS, INC.**

Job Address

**ICC-ES Evaluation
Report Number** _____

Date of Job Completion _____

Plastering Contractor

Name: _____

Address: _____

Telephone No.: (_____) _____

Approved contractor number as issued by the coating manufacturer _____

This is to certify that the exterior coating system on the building exterior at the above address has been installed in accordance with the evaluation report specified above and the manufacturer's instructions.

Signature of authorized representative
of plastering contractor

Date

This installation card must be presented to the building inspector after completion of work and before final inspection.

FIGURE 3—INSTALLATION CARD